



PHOENIX AMERICA INC.

4717 CLUBVIEW DRIVE
FORT WAYNE, IN 46804

P16A

Radial, Multi-Pole Magnet Target Wheels

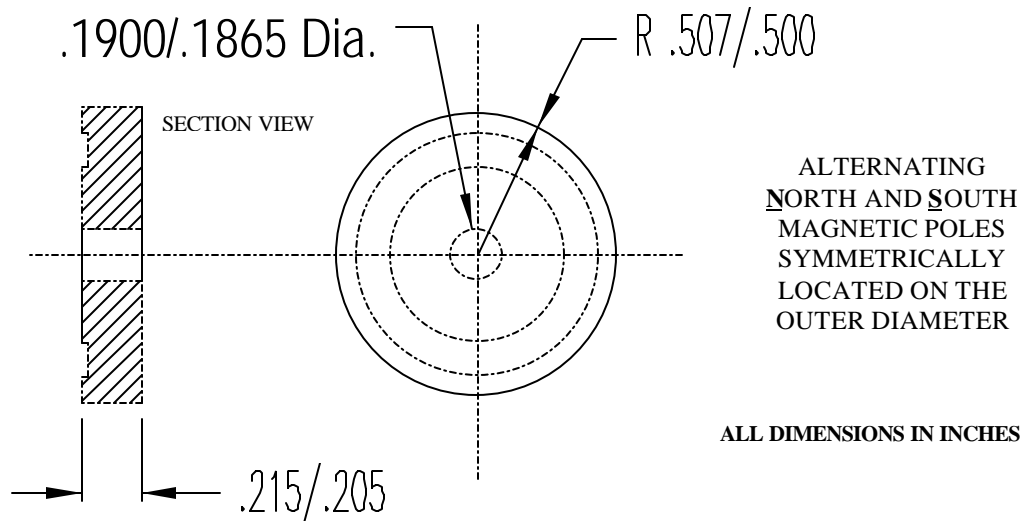

FEATURES:

- Rugged, chip free construction
- Wide range of pole counts
- Three grades of magnetic materials
- High resistance to demagnetization
- Operation from -40°C to 125°C
- Well suited for general industrial environments
- Recommended attachment method: Adhesive bonding
- Many additional, non-stocked pole counts available

Magnet Target Description:

Bonded multi-pole magnet rotors are used in a wide variety of speed and commutation applications such as to rotary encoders, speedometers and machine controls. Three standard grades of magnetic materials are offered to fulfill a broad spectrum of magnetic field requirements along with a high resistance to demagnetization. Combined with a Nylon polymer binder, they offer excellent dimensional control and tough environmental endurance. Multi-pole rotors can be modified to have other pole patterns, custom compounded binders, or metal inserts for specialized applications.

ORDERING INFORMATION:

MATERIAL DESIGNATION			
	Magnalox 300	Neobond 12M	Neobond 30M
NUMBER OF POLES	2	P16A25R2	P16A50R2
	4	P16A25R4	P16A50R4
	8	P16A25R8	P16A50R8
	16	P16A25R16	P16A50R16
	30	P16A25R30	P16A50R30
	40	P16A25R40	P16A50R40
	60	P16A25R60	P16A50R60