



PHOENIX AMERICA INC.

4717 CLUBVIEW DRIVE
FORT WAYNE, IN 46804

P16C

Radial, Multi-Pole Magnet Target Wheels

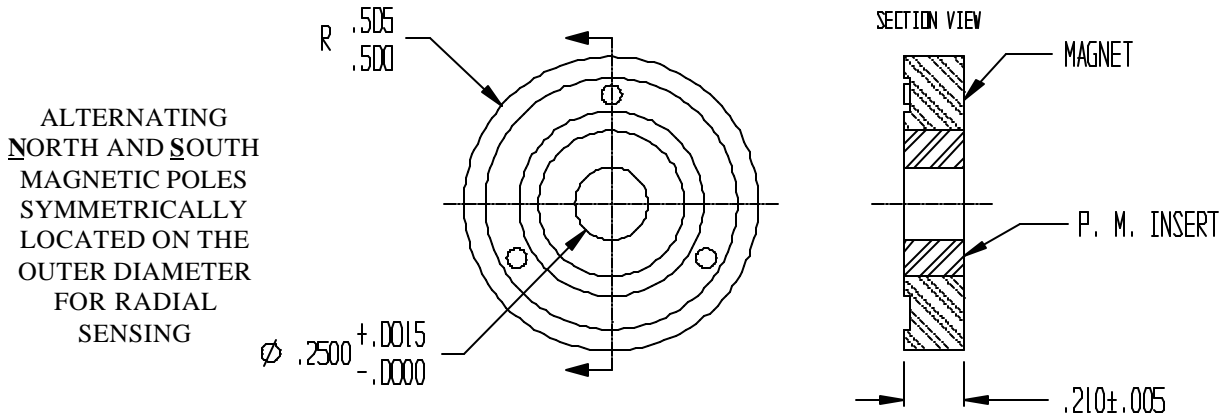

FEATURES:

- Wide range of pole counts
- Three grades of magnetic materials
- Powder metal hub for press fit or bolt-through mounting
- High resistance to demagnetization
- Operation from -40°C to 125°C
- Tough environmental endurance
- Very resistant to chipping

Magnet Target Description:

Bonded multi-pole magnet rotors are used in a wide variety of speed and commutation applications such as to rotary encoders, speedometers and machine controls. Three standard grades of magnetic materials are offered to fulfill a broad spectrum of magnetic field requirements along with a high resistance to demagnetization. Combined with a Nylon polymer binder, they offer excellent dimensional control and tough environmental endurance. Multi-pole rotors can be modified to have other pole patterns, custom compounded binders, or metal inserts for specialized applications.

ORDERING INFORMATION:

MATERIAL DESIGNATION			
	Magnalox 300	Neobond 12M	Neobond 30M
NUMBER OF POLES	2	P16C25R2	P16C50R2
	4	P16C25R4	P16C50R4
	8	P16C25R8	P16C50R8
	16	P16C25R16	P16C50R16
	30	P16C25R30	P16C50R30
	40	P16C25R40	P16C50R40
	60	P16C25R60	P16C50R60