

4

3

2

1

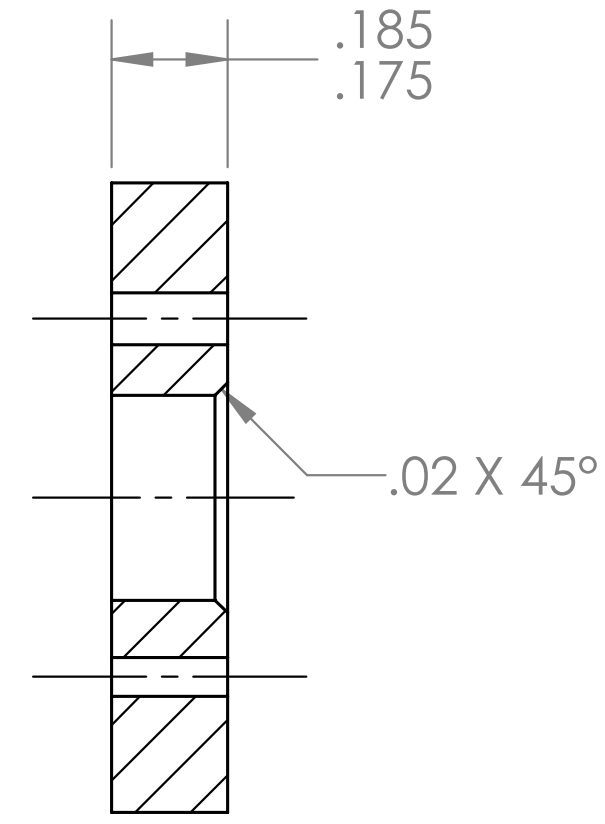
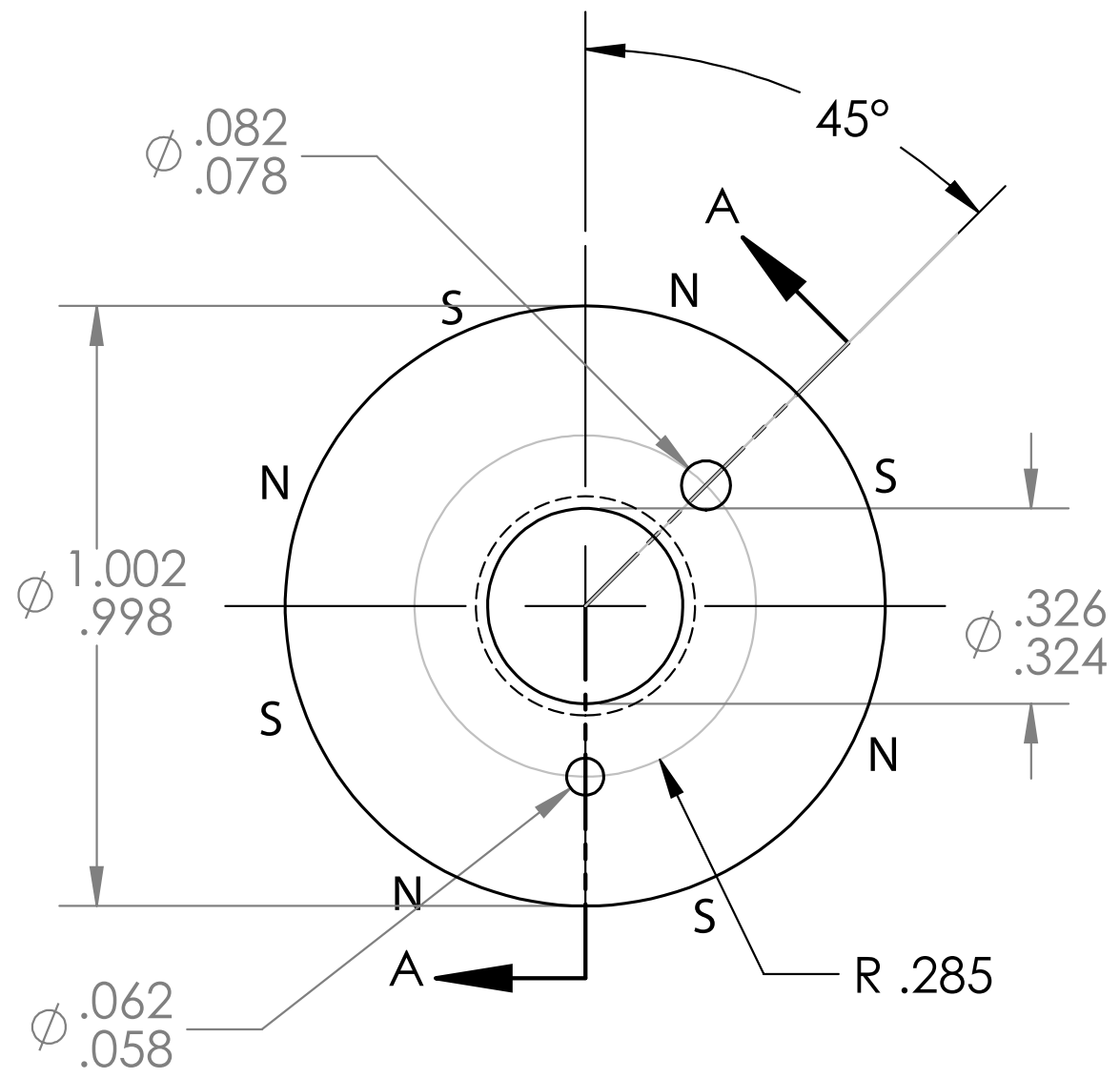

SECTION A-A

PROPRIETARY AND CONFIDENTIAL
 THE INFORMATION CONTAINED IN THIS DRAWING IS THE SOLE PROPERTY OF <INSERT COMPANY NAME HERE>. ANY REPRODUCTION IN PART OR AS A WHOLE WITHOUT THE WRITTEN PERMISSION OF <INSERT COMPANY NAME HERE> IS PROHIBITED.

		UNLESS OTHERWISE SPECIFIED:	NAME	DATE	TITLE:
		DIMENSIONS ARE IN INCHES	DRAWN		
		TOLERANCES:	CHECKED		
		FRACTIONAL \pm	ENG APPR.		
		ANGULAR: MACH \pm BEND \pm	MFG APPR.		
		TWO PLACE DECIMAL \pm	Q.A.		SIZE DWG. NO. REV 206M008_sketch
		THREE PLACE DECIMAL \pm	COMMENTS:		
		INTERPRET GEOMETRIC TOLERANCING PER:			
NEXT ASSY	USED ON	MATERIAL			
APPLICATION		FINISH	SCALE: 2:1 WEIGHT: SHEET 1 OF 1		
		DO NOT SCALE DRAWING			

4

3

2

1