

Encoder Mounting Guidelines

Concentricity of the encoder housing to the target magnet is critical for optimal encoder performance. Considering the following during the design phase will ensure concentricity and ease of assembly.

- Tight molding tolerances allow for the outside diameter of the encoder to be used to locate the encoder housing concentric to the motor shaft and target magnet. A machined pocket on the motor endbell works well for alignment. Recommended pocket is 0.015" to 0.020" deep and 2.11" in diameter.
- Extending the shaft through the optional shaft pass through hole is an easy way to align the encoder housing to the motor shaft and target magnet. Simply position the encoder so that the shaft is centered concentrically in the shaft pass through hole.
- If previous two methods of alignment are not used it is recommended that the encoder be fastened to the motor using #5-40 or M3 mounting screws. The slightly larger diameter of the #5-40 and M3 screws will compensate for some of the tolerance allowed when using the standard recommended #4-40 or M2.5 mounting screws.

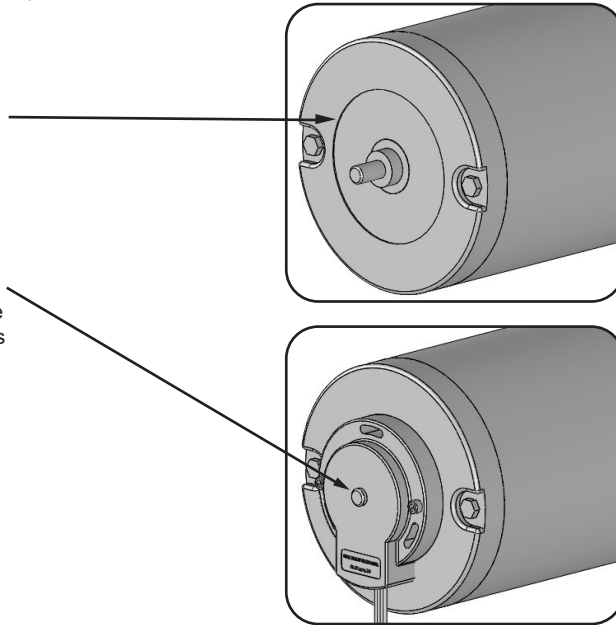

Target Magnet Mounting Guidelines - Molded (Mounting Style A) For Slip Fit Application

- Proper alignment of the target magnet to the encoder sensing element is critical for optimal encoder performance. Insure that the target magnet is mounted to the specified height shown in the diagram below.
- A machined step on the motor shaft provides a quick and repeatable method for positioning the target magnet. Spacers or other fixturing should be used to properly position the target magnet if no mechanical locating features are on the shaft.
- Various adhesives can be used to bond the target magnet to the motor shaft. Shaft alloys, operating environment, and shaft speed and acceleration should be taken into consideration when selecting an appropriate bonding agent. Loctite threadlockers and retaining compounds have proved effective in bonding the target magnet to the motor shaft. Loctite 263 and 2760 threadlockers and Loctite 638 and 680 retaining compounds are good candidates. These materials have been effective in past experience; testing under actual operating conditions should be used to qualify any bonding material.
- For best results, the motor shaft should be clean and free of any oils, lubricants, or solvents.
- Apply adhesive around the leading edge of the shaft and inside the hole in the target magnet. Use a rotating motion when assembling the target magnet to the shaft to insure good adhesive coverage.
- The use of primers and activators can be used to improve bond strength and cure rate.
- For non-critical applications or for fast bonding for evaluation, a cyanoacrylate adhesive (super glue) can be used. Loctite 401 and 410 have proven effective for quick bonding applications.

