

Encoder Mounting Guidelines

- Air gap between magnet rotor and encoder housing should be set to the minimum that can be achieved, taking into account radial play and mounting tolerances. 0.010" to 0.020" is a good target. Air gaps greater than 0.040" are acceptable depending on resolution, pole count, and external environment.
- The encoder and rotor should be mounted perpendicular to the shaft the rotor is mounted on.
- The image below shows a two inch magnet rotor, but alignment targets hold true for all magnet rotor sizes.

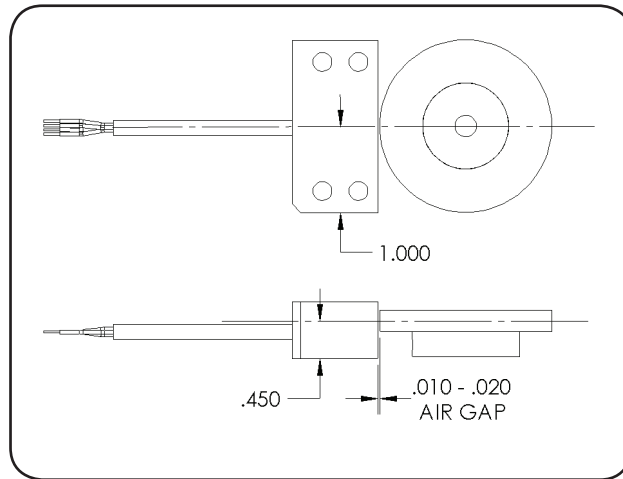

Target Rotor Mounting Guidelines - Aluminum Hub (Mounting Style B)

- Proper alignment of the target rotor to the encoder sensing element is critical for optimal encoder performance. Insure that the rotor is mounted to the specified height using one of the options shown in the diagram below.
- A machined step on the motor shaft provides a quick and repeatable method for positioning the target rotor. Spacers or other fixturing should be used to properly position the rotor if no mechanical locating features are on the shaft.
- While the hub is held in the proper position, use a hex wrench to tighten #10-32 set screw.
- For permanent applications, a threadlocker or retaining compound is advised in conjunction with the set screw.

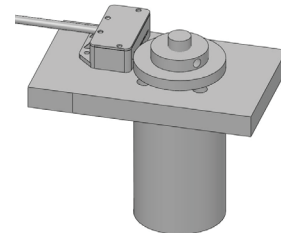
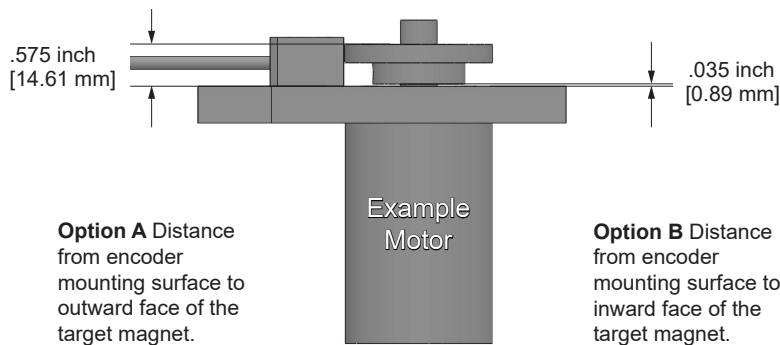

Images show two inch magnet rotor, but alignment targets hold true for all sizes.