

Features and Benefits

- Four grades of magnetic materials
- Cost effective design
- High resistance to demagnetization
- Operation from -40°C to 125°C
- Tough environmental endurance
- Very resistant to chipping

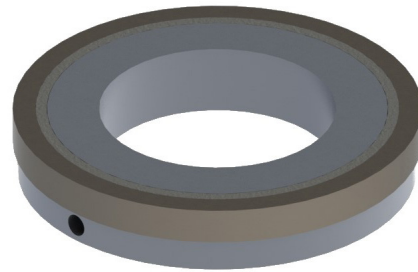

Molded Target Magnet

Physical Properties of Magnetic Material

Table 1.1

Characteristic	Value	Units
Tensile Strength	6500	PSI
Flexural Strength	9750	PSI
Flexural Modulus	1.3 X 10 ⁶	PSI
Continuous Service Temperature	100	°C

Magnetic Properties

Table 1.2

Characteristic	Magnalox 300	Neobond 12M	Neobond 30M	Neobond 32P	Units
Remanence (B _r)	1370	2500	4000	4300	Gauss
Coercive Force (H _c)	1180	2400	3250	2500	Oersted
Energy Product (BH _{MAX})	0.40	1.3	3.1	3.2	MGOe
Intrinsic Coercive Force (H _{ci})	2300	7500	7000	6900	Oersted
Reversible Temperature Coefficient (B _r)	-0.2	-0.35	-0.4	-0.4	%/degC
Reversible Temperature Coefficient (H _{ci})	+0.5	-0.25	-0.36	-0.40	%/degC
Peak Magnetizing Force (>95% Saturation)	596	1100	1600	1600	kA/m
Specific Gravity	3.5	4.0	4.7	4.45	---

Pole Counts

Alternating north and south magnetic poles are symmetrically located on the outer diameter for radial sensing.

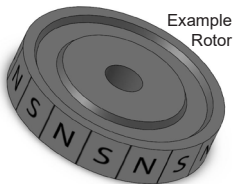

Note: (N)orth/(S)outh markings are for illustration and do not appear on the actual product.

Available Pole Counts	32, 36, 50, 64, 120
-----------------------	---------------------

Target Rotor Physical Outline - Aluminum Hub (Mounting Style B)

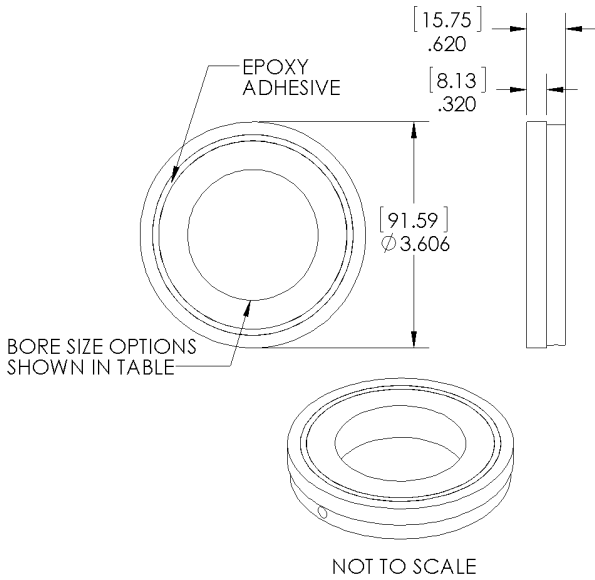

Table 3.1

	Motor Shaft OD Size (nominal)	NEMA Guide Shaft Tolerance	Magnet Bore MIN. (inch)	Magnet Bore MAX. (inch)
1000	1 in (1.0000")	+0.0000"/-0.0005"	1.0009	1.0020
1125	1 1/8 in (1.1250")		1.1259	1.1270
1182	30 mm (1.1820")		1.1829	1.1840
1375	1 3/8 in (1.3750")		1.3759	1.3770
1500	1 1/2 in (1.5000")		1.5009	1.5020
1625	1 5/8 in (1.6250")		1.6259	1.6270
1875	1 7/8 in (1.8750")		1.8759	1.8770
2000	2 in (2.0000")		2.0009	2.0020
2125	2 1/8 in (2.1250")		2.1259	2.1270
2250	2 1/4 in (2.2500")		2.2509	2.2520
2375	2 3/8 in (2.3750")		2.3759	2.3770
2500	2 1/2 in (2.5000")		2.5009	2.5020
2750	2 3/4 in (2.7500")		2.7509	2.7520

Other bore sizes available upon request.
Contact sales@phoenixamerica.com.

Target Rotor Mounting Guidelines - Aluminum Hub (Mounting Style B)

- Proper alignment of the target rotor is critical for optimal performance.
- A machined step in the motor shaft provides a quick and repeatable method for positioning the target rotor. Spacers or other fixturing should be used to properly position the rotor if no mechanical locating features are on the shaft.
- While the hub is held in the proper position, use a hex wrench to tighten #10-32 set screw.
- For permanent applications, a threadlocker or retaining compound is advised in conjunction with the set screw.

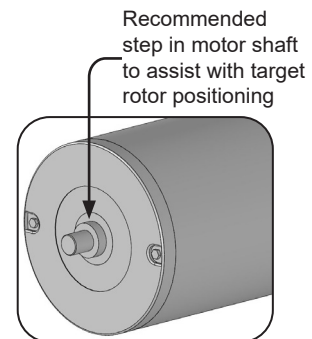
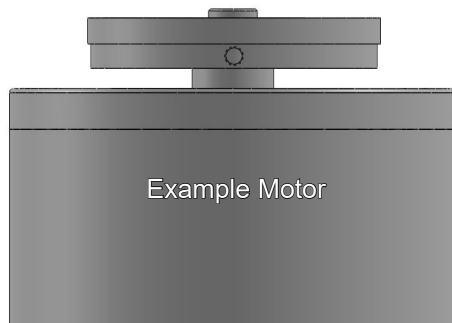

Part Number Description

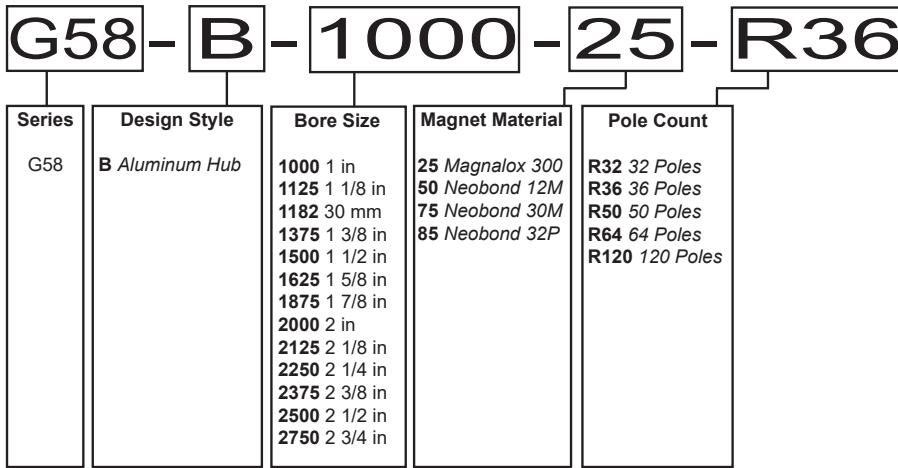

Example: G58-B-1000-25-R36