

Features and Benefits

- Magnetic technology offers robust performance.
- 100% Non-contacting design (no bearings or bushing) provides an extremely long life expectancy and is tolerant to harsh environments.
- Simple two piece design (target magnet + encoder) for easy alignment and installation.
- Bi-directional two channel incremental quadrature output. Option for differential RS422 compatible output.
- Mounting holes for a 2-bolt pattern 1.280 inch B.C. x 0.125 inch O.D.
- Target magnet for standard shaft sizes from 5/8 inch to 1 1/8 inch. Custom bore size available.
- Options for 32 to 2048 pulse per channel per revolution (*increments of 32*).
- Customizable lead wires, cables, and or connectors.

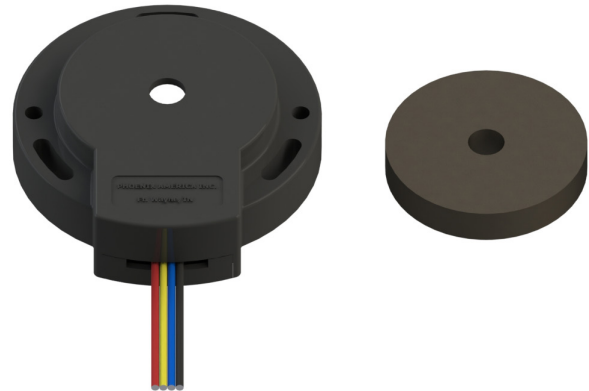

Kit - Encoder with Target Magnet
Shown with shaft pass through hole and single ended wiring
Wire color order varies with part configuration

Application Example

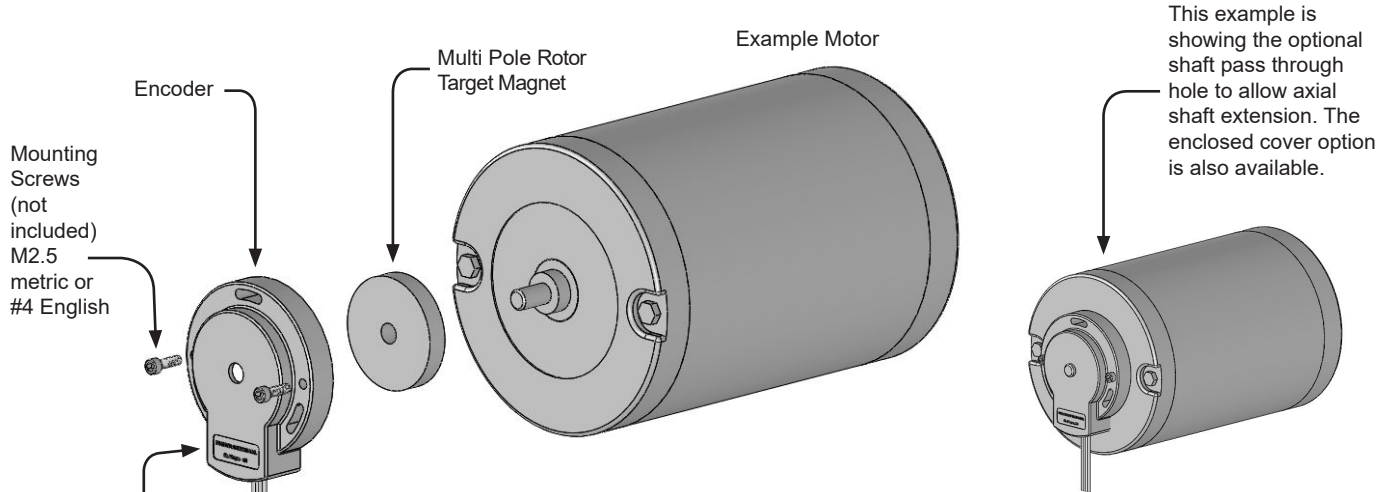
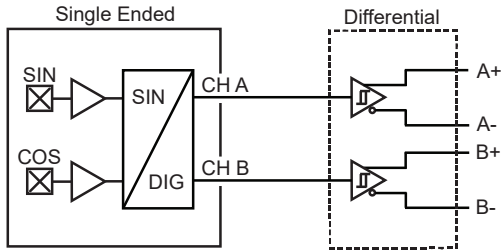

Table 1.1

Standard Wiring Color Code				
		Flying Leads	Cable	
Differential	Single Ended	Vcc	Red	
		Gnd	Black	
		Ch A	Yellow	
	Ch B	Blue		
	Differential	Ch A-	Brown	Yellow
		Ch B-	Orange	Green

Other colors available upon request.
Contact sales@phoenixamerica.com.

Electrical Circuit



Absolute Maximum Ratings

Table 2.1

Characteristic	Symbol	Rating for 5V	Rating for 6V to 25V	Units
Forward Supply Voltage	V_{CC}	6	30	V
Reverse Supply Voltage	V_{RCC}	-0.3	-20	V
Storage Temperature	T_s	150	150	°C
ESD (HMB, 100pF/1.5Kohm)		2	2	kV

Specifications - 5V Supply

Table 2.2

Characteristic	Symbol	Test Conditions	Min.	Typ.	Max.	Unit
Supply Voltage	V_{CC}	Operating, $T_J < 165\text{ °C}$	4.75	5	5.5	V
Supply Current	I_{CC}	$V_{CC} = 12V$	-	15	24	mA
Operating Temperature	T_A		-40	-	125	°C
Duty Cycle	-		40	50	60	%
Phase	-		70	90	110	°e
Output Frequency	f_{out}		-	-	300	kHz

Specifications - 24V Supply

Table 2.3

Characteristic	Symbol	Test Conditions	Min.	Typ.	Max.	Unit
Supply Voltage	V_{CC}	Operating, $T_J < 165\text{ °C}$	5.0	12	24	V
Supply Current	I_{CC}	$V_{CC} = 12V$	-	15	25	mA
Operating Temperature	T_A		-40	-	125	°C
Duty Cycle	-		40	50	60	%
Phase	-		70	90	110	°e
Output Frequency	f_{out}		-	-	300	kHz

Higher output frequencies available upon request. Contact sales@phoenixamerica.com.

Output Waveforms

Single Ended

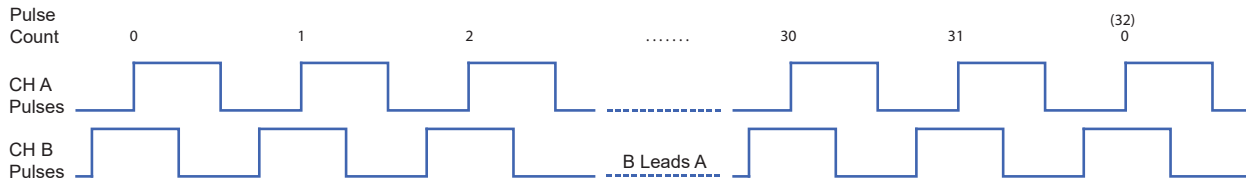
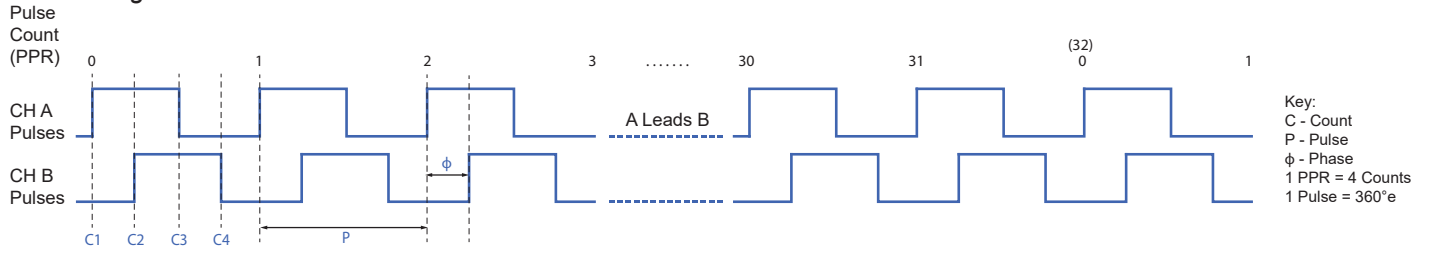

Differential

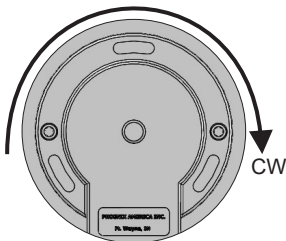
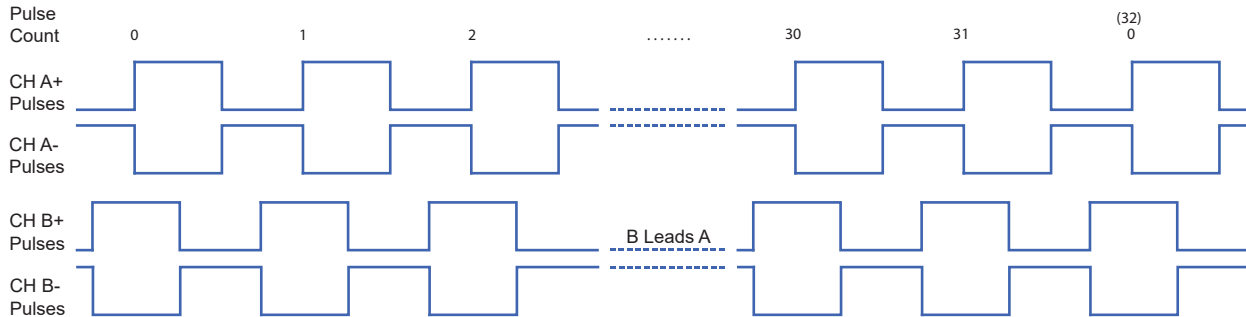
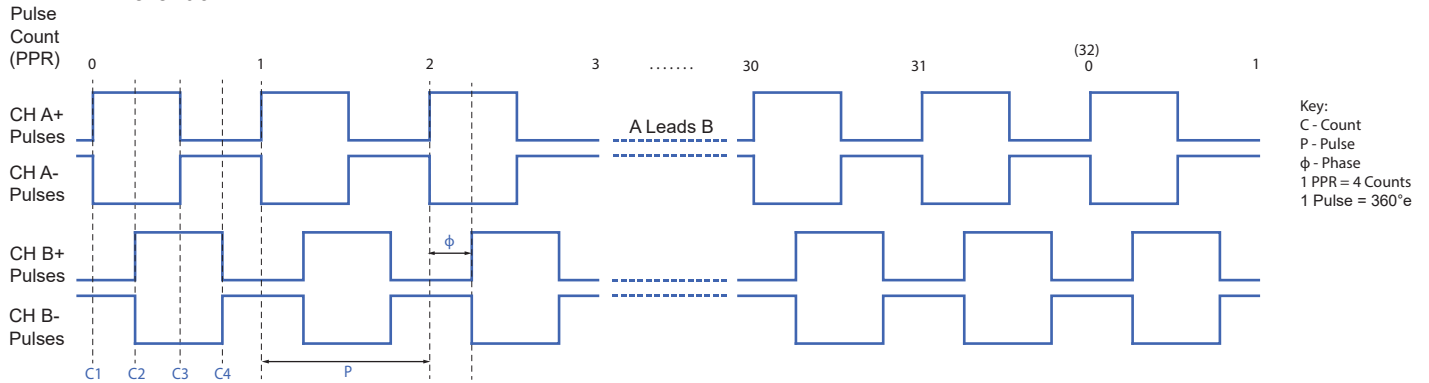

Channel A leads Channel B for clockwise shaft rotation (shaft rotation is defined when looking at the branded face of the encoder).

Encoder Physical Outline

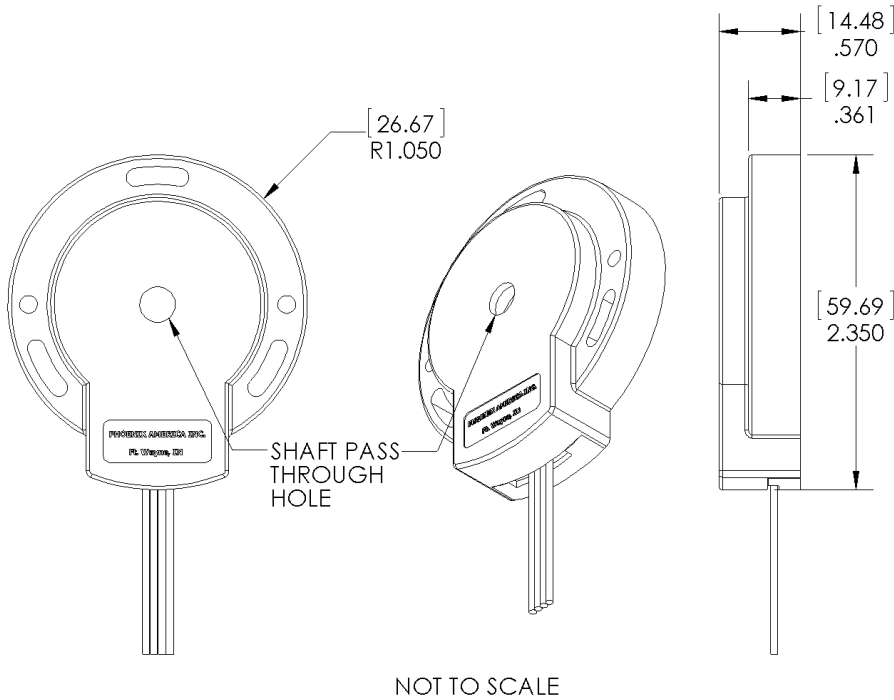

Table 4.1

Motor Shaft Diameter	Shaft Pass Through Hole Size (options/recommendation)	
-	No Hole	
5/8 in	15.91 mm	0.627 in
19 mm	19.06 mm	0.751 in
3/4 in	19.09 mm	0.752 in
7/8 in	22.26 mm	0.877 in
24 mm	24.06 mm	0.948 in
1 in	25.43 mm	1.002 in
28 mm	28.06 mm	1.106 in
1 1/8 in	28.60 mm	1.127 in

Other shaft pass through hole sizes available upon request. Contact sales@phoenixamerica.com.

Encoder Mounting Guidelines

Concentricity of the encoder housing to the magnet rotor is critical for optimal encoder performance. Considering the following during the design phase will ensure concentricity and ease of assembly.

- Tight molding tolerances allow for the outside diameter of the encoder to be used to locate the encoder housing concentric to the motor shaft and magnet rotor. A machined pocket on the motor endbell works well for alignment. Recommended pocket is 0.015" to 0.020" deep and 2.11" in diameter.
- Extending the shaft through the optional shaft pass through hole is an easy way to align the encoder housing to the motor shaft and magnet rotor. Simply position the encoder so that the shaft is centered concentrically in the shaft pass through hole.
- If previous two methods of alignment are not used it is recommended that the encoder be fastened to the motor using #5-40 or M3 mounting screws. The slightly larger diameter of the #5-40 and M3 screws will compensate for some of the tolerance allowed when using the standard recommended #4-40 or M2.5 mounting screws.

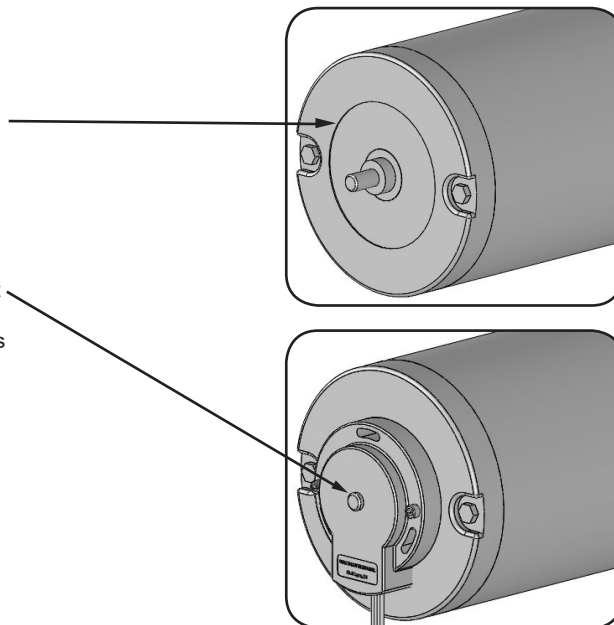

Target Rotor Physical Outline - Molded (Mounting Style A)

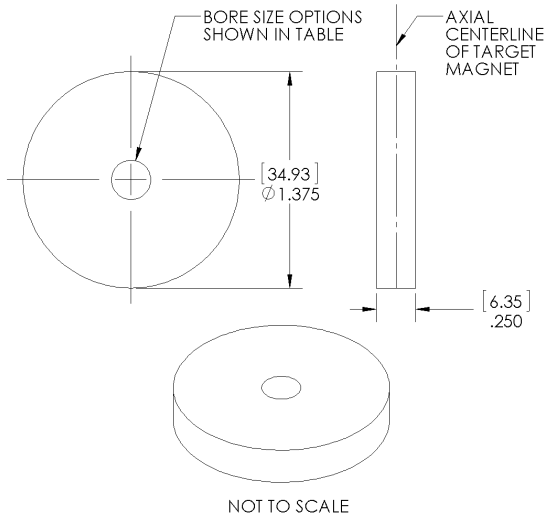

Table 5.1

Bore Size (inch)	Motor Shaft OD Size (nominal)	NEMA Guide Shaft Tolerance	Magnet Bore MIN. (inch)	Magnet Bore MAX. (inch)
0625	5/8 in (.625")	+0.0000"/-0.0005"	.627	.629
0748	19 mm (.748")		.750	.757
0750	3/4 in (.750")		.757	.759
0875	7/8 in (.875")		.877	.879
0945	24 mm (.945")		.947	.949
1000	1 in (1.000")		1.002	1.004
1102	28 mm (1.102")		1.104	1.106
1125	1 1/8 in (1.125")		1.127	1.129

Other bore sizes available upon request.
Contact sales@phoenixamerica.com.

Target Rotor Mounting Guidelines - Molded (Mounting Style A) For Slip Fit Application

- Proper alignment of the target rotor to the encoder sensing element is critical for optimal encoder performance. Insure that the rotor is mounted to the specified height shown in the diagram below.
- A machined step on the motor shaft provides a quick and repeatable method for positioning the target rotor. Spacers or other fixturing should be used to properly position the rotor if no mechanical locating features are on the shaft.
- Various adhesives can be used to bond the target rotor to the motor shaft. Shaft alloys, operating environment, and shaft speed and acceleration should be taken into consideration when selecting an appropriate bonding agent. Loctite threadlockers and retaining compounds have proved effective in bonding the target rotor to the motor shaft. Loctite 263 and 2760 threadlockers and Loctite 638 and 680 retaining compounds are good candidates. These materials have been effective in past experience; testing under actual operating conditions should be used to qualify any bonding material.
- For best results, the motor shaft should be clean and free of any oils, lubricants, or solvents.
- Apply adhesive around the leading edge of the shaft and inside the hole in the rotor. Use a rotating motion when assembling the magnet to the shaft to insure good adhesive coverage.
- The use of primers and activators can be used to improve bond strength and cure rate.
- For non-critical applications or for fast bonding for evaluation, a cyanoacrylate adhesive (super glue) can be used. Loctite 401 and 410 have proven effective for quick bonding applications.

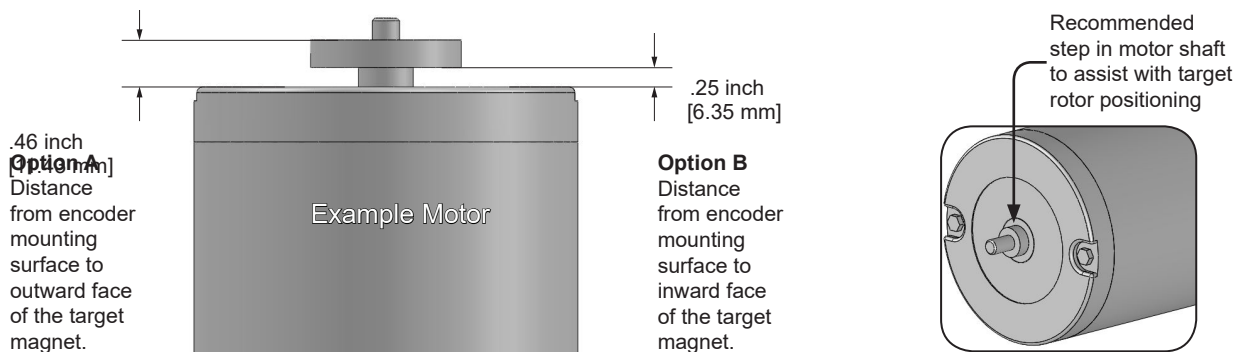

Wiring (Single ended option depicted)

FLYING LEADS

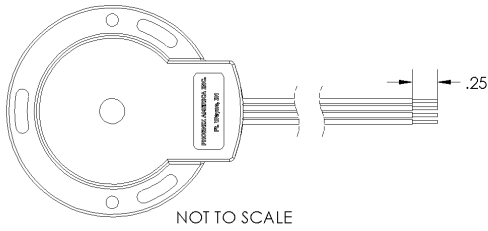

- 24 AWG
- 7x32 Strands, Tinned Copper
- PVC Insulation
- UL Type 1430
- Temperature Rating: 105°C

CABLE

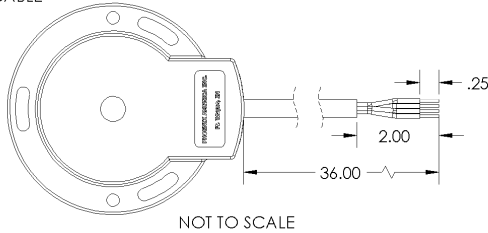

- 24 (or 26) AWG
- 4 (or 6) Conductor with Foil Shield and Drain
- Stranded Tinned Copper
- PVC Insulation
- Grey PVC Jacket
- UL Style 2464, CSA
- Temperature Rating: 105°C

Table 6.1

Single Ended Wiring			
	Leads	Cable	Connector Pin-Out
Ch A	Yellow	Brown	1
Ch B	Blue	Orange	2
Gnd	Black	Black	3
Vcc	Red	Red	4
Differential Wiring			
	Leads	Cable	Connector Pin-Out
Ch B	Blue	Orange	1
Ch B-	Orange	Green	2
Ch A	Yellow	Brown	3
Ch A-	Brown	Yellow	4
Gnd	Black	Black	5
Vcc	Red	Red	6

Custom lengths and insulation materials available. Contact sales@phoenixamerica.com.

Connector Options (Single ended option depicted)

Molex Mini-Fit Jr. (Male)

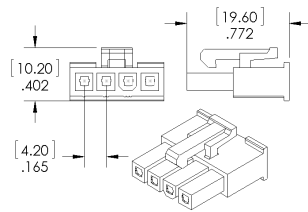

Molex Mini-Fit Jr. (Female)

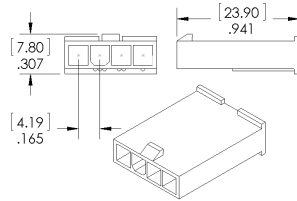

TE AmpModu MTE (Male)

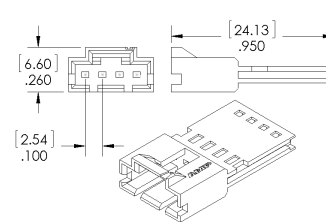

TE AmpModu MTE (Female)

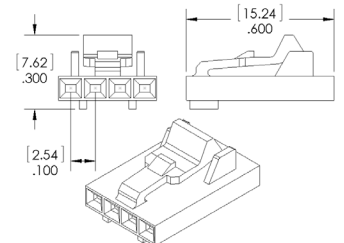

Need a different connector? Contact sales@phoenixamerica.com.

Part Number Description

Series	PPR	Bore Size	Supply Voltage	Index	Output Type	Shaft Pass Through Hole	Target Magnet Mounting	Wiring	Length (Meters)	Connector
HJ	32 64 96 . . 2028	0625 5/8 in (default) 0748 19 mm 0750 3/4 in 0875 7/8 in 0945 24 mm 1000 1 in 1102 28 mm 1125 1 1/8 in	05 5 V (default) 24 24 V	N A,B Quadrature (default)	S Single-Ended (default) D Differential	N None (default) Y Hole size will match Table 4.1	A Molded (default)	F Flying Leads (default) C Cable	A .5 (19.685") B 0.914 (36") (default) C 1 (39.370") D 2 (78.740")	X None (default) A1 TE AmpModu MTE (Male) A2 TE AmpModu MTE (Female) M1 Molex Mini-Fit Jr. (Male) M2 Molex Mini-Fit Jr. (Female)

Example: HJ-32-0625-05-N-S-N-A-F-B-X