

Features and Benefits

- Magnetic technology offers robust performance.
- 100% Non-contacting design (no bearings or bushings) provides an extremely long life expectancy and is tolerant to harsh environments.
- Simple two piece design (target magnet + encoder) for easy alignment and installation.
- Output options: Two channel (AB), Two channel with index (ABZ), Differential (AB) outputs, and Differential outputs with index (ABZ)
- Mounting holes for a 2-bolt pattern 1.280 inch BHC x 0.125 inch O.D.
- Target magnet for standard shaft sizes from 2 mm to 1/2 inch. Custom bore sizes available.
- Optional universal target magnet hub to accommodate both metric (2, 4, 5, 6 & 8mm) and inch (1/8, 3/16, 1/4, 5/16 & 3/8 In.) shaft diameters
- Options for 32 - 2560 pulse per channel per revolution.
- Customizable lead wires, cables, and/or connectors.



Kit - Encoder with Target Magnet
Shown with shaft pass through hole and single ended wiring
Wire color order varies with part configuration

Application Example

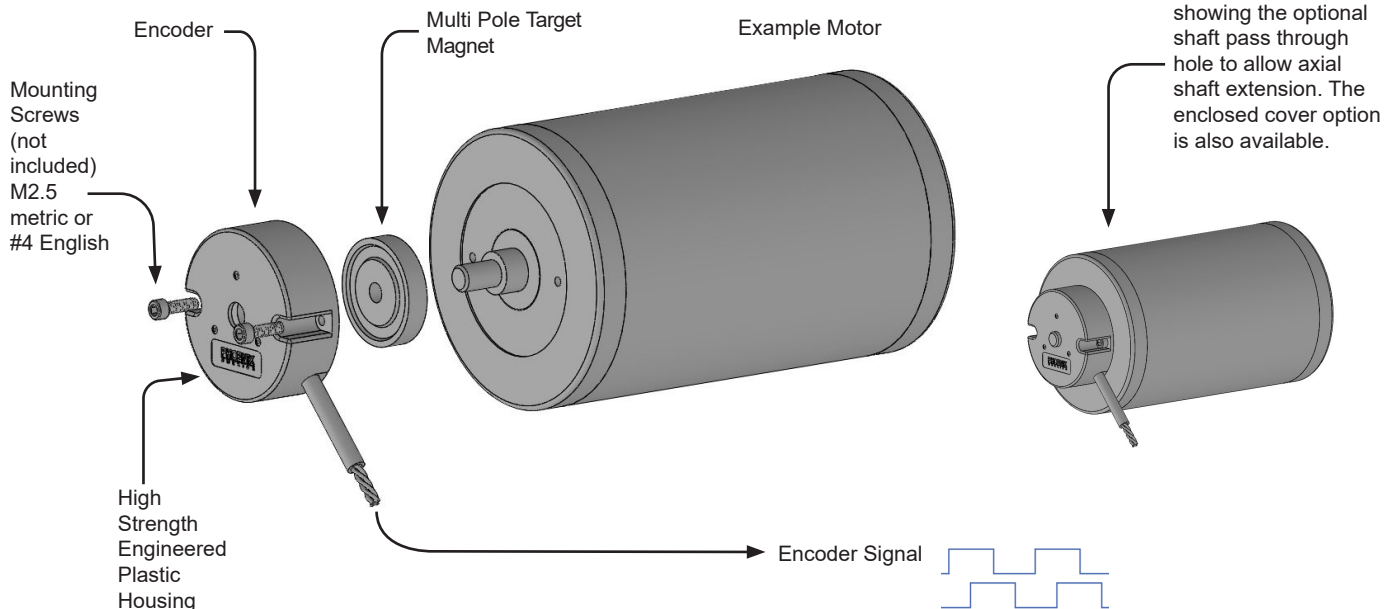

Electrical Circuit

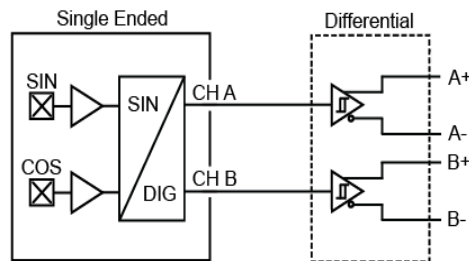

Absolute Maximum Ratings

Table 2.1

Characteristic	Symbol	Rating	Units
Forward Supply Voltage	V_{CC}	12	V
Reverse Supply Voltage	V_{RCC}	-0.3	V
Storage Temperature	T_s	150	°C
ESD (HMB, 100pF/1.5Kohm)		2	kV
Operating Temperature		-40 to 125	°C

Electrical Specifications - ($V_{CC} = 5V$, Ambient Temperature = 23°C)

Table 2.2

Characteristic	Symbol	Min.	Typ.	Max.	Unit
Supply Voltage	V_{CC}	3.3	5	6	V
Supply Current	I_{CC}	-	14	20	mA
Duty Cycle	-	40	50	60	%
Phase	-	70	90	110	°e
Output Frequency	f_{out}	-	-	42	kHz

Output Waveforms

Single Ended

Single Ended - Clockwise Rotation

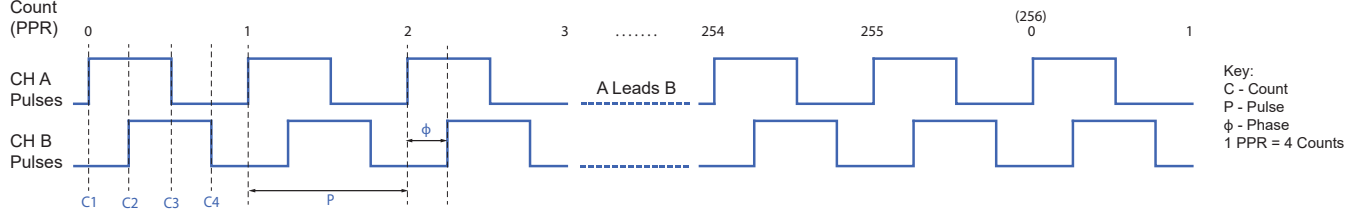

Z Option - Clockwise Rotation

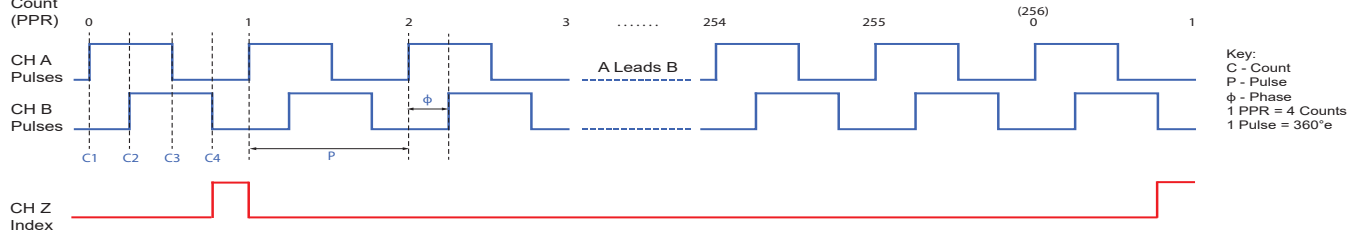

Differential

Differential - Clockwise Rotation

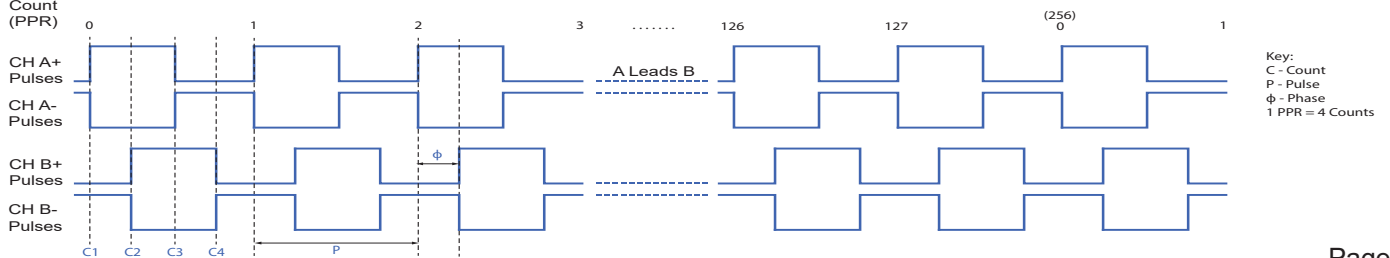

Output Waveforms (Continued)

Differential -Z Option

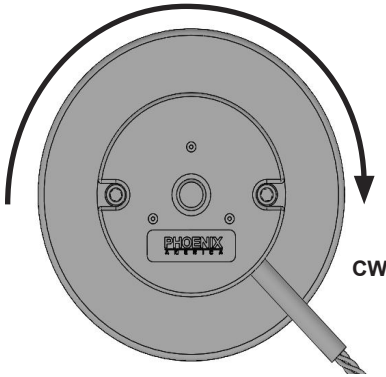
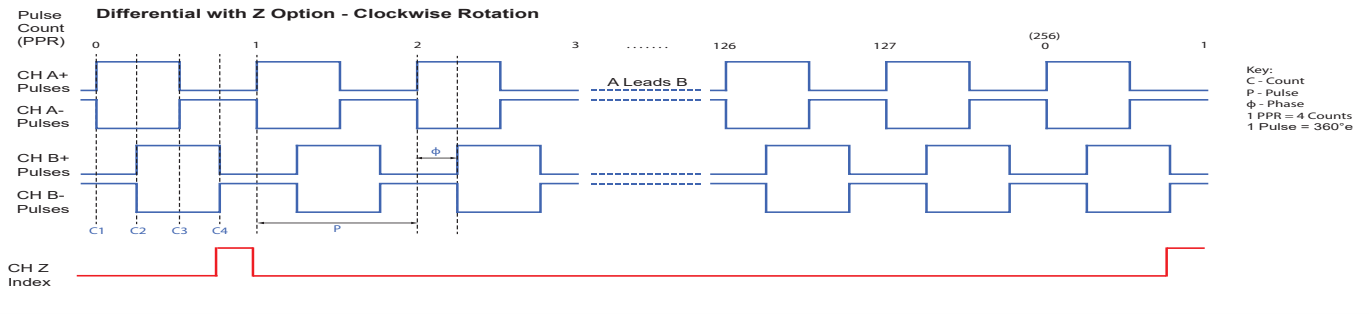

Channel A leads Channel B for clockwise rotation (Shaft rotation is defined when looking at the branded face of the encoder)

Encoder Physical Outline

Cable Version with Strain Relief

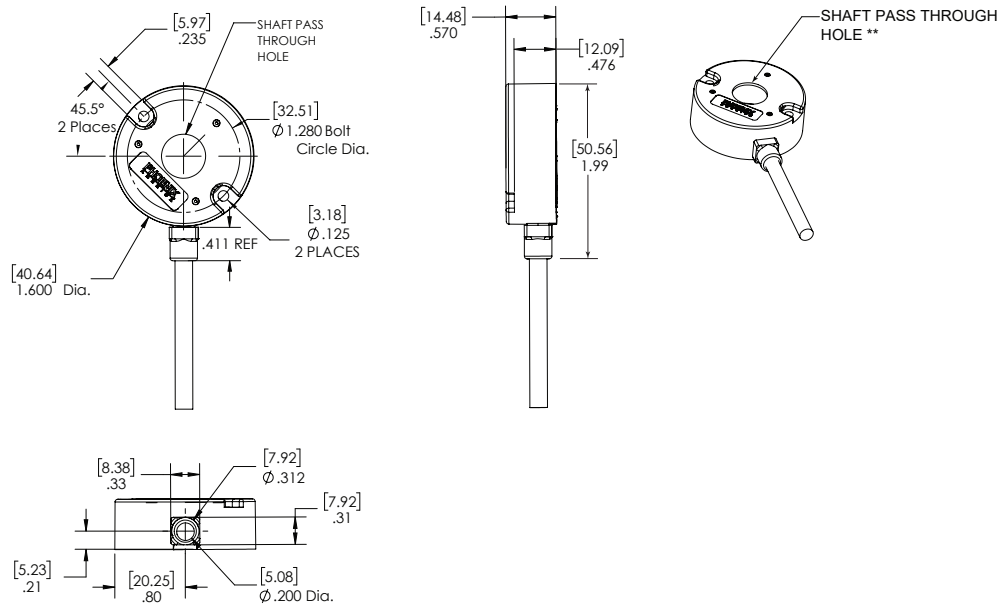

Encoder Physical Outline

Flying Lead Version with Strain

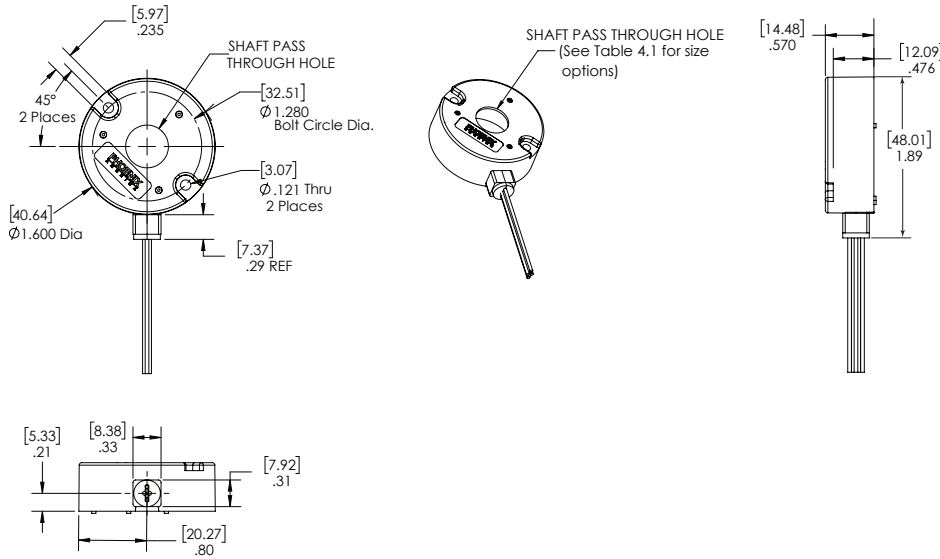

Table 4.1

Motor Shaft Diameter	Shaft Pass Through Hole Size (options/recommendation)	
-	No Hole	
2 mm	2.06 mm	0.081 in
3 mm	3.06 mm	0.120 in
1/8 in	3.26 mm	0.127 in
5/32 in	4.06 mm	0.160 in
4 mm	4.06 mm	0.160 in
3/16 in	4.83 mm	0.190 in
5 mm	5.06 mm	0.199 in
6 mm	6.06 mm	0.239 in
1/4 in	6.40 mm	0.252 in
7 mm	7.06 mm	0.278 in
5/16 in	8.05 mm	0.317 in
8 mm	8.05 mm	0.317 in
3/8 in	9.59 mm	0.378 in
10 mm	10.06 mm	0.396 in
12 mm	12.06 mm	0.475 in
1/2 in	12.76 mm	0.502 in

Other shaft pass through hole sizes available upon request. Contact sales@phoenixamerica.com.

Encoder Mounting Guidelines

Concentricity of the encoder housing to the target magnet is critical for optimal encoder performance. Considering the following during the design phase will ensure concentricity and ease of assembly.

- Tight molding tolerances allow for the outside diameter of the encoder to be used to locate the encoder housing concentric to the motor shaft and target magnet. A machined pocket on the motor endbell works well for alignment. Recommended pocket is 0.015" to 0.020" deep and 2.11" in diameter.
- Extending the shaft through the optional shaft pass through hole is an easy way to align the encoder housing to the motor shaft and target magnet. Simply position the encoder so that the shaft is centered concentrically in the shaft pass through hole.
- If previous two methods of alignment are not used it is recommended that the encoder be fastened to the motor using #5-40 or M3 mounting screws. The slightly larger diameter of the #5-40 and M3 screws will compensate for some of the tolerance allowed when using the standard recommended #4-40 or M2.5 mounting screws.

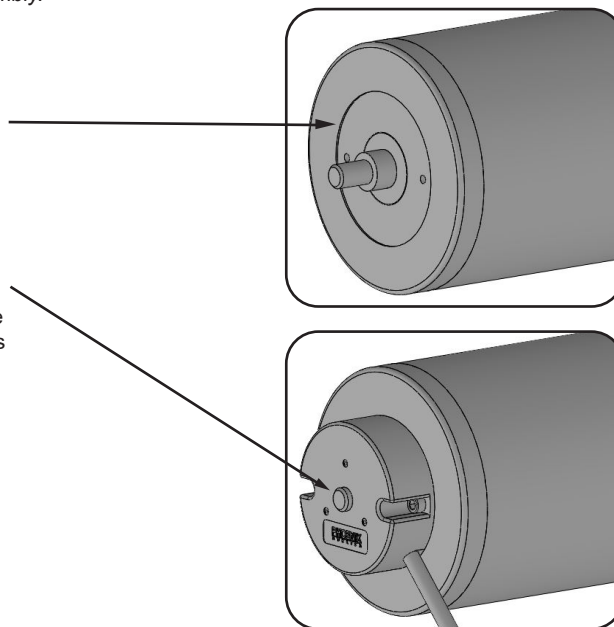

Target Magnet Physical Outline - Molded (Mounting Style A)

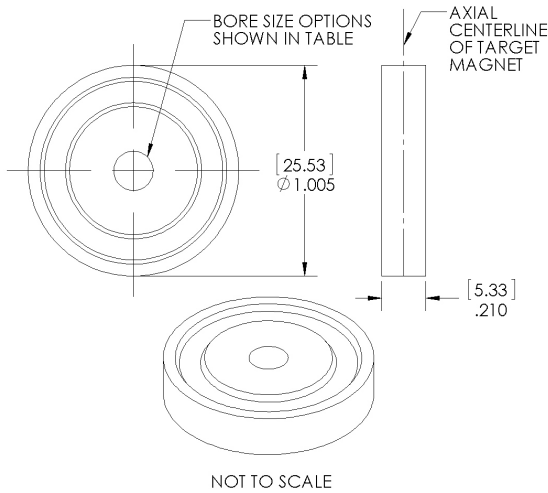

Table 5.1

Bore Size (.inch)	Motor Shaft OD Size (nominal)	NEMA Guide Shaft Tolerance	Magnet Bore MIN. (inch)	Magnet Bore MAX. (inch)
079	2 mm (.0787")	+0.0000"/-0.0005"	.0777	.0807
118	3 mm (.1181")		.1171	.1201
125	1/8 in (.1250")		.1240	.1270
156	5/32 in (.1563")		.1553	.1583
157	4 mm (.1575")		.1565	.1595
188	3/16 in (.1875")		.1865	.1895
197	5 mm (.1969")		.1959	.1989
236	6 mm (.2364")		.2354	.2384
250	1/4 in (.2500")		.2490	.2520
276	7 mm (.2758")		.2747	.2777
313	5/16 in (.3125")		.3115	.3145
315	8 mm (.3150")		.3140	.3170
375	3/8 in (.3750")		.3740	.3770
394	10 mm (.3940")		.3930	.3960
473	12 mm (.4728")		.4718	.4748
500	1/2 in (.5000")		.4990	.5020

Other bore sizes available upon request.
Contact sales@phoenixamerica.com.

Target Magnet Mounting Guidelines - Molded (Mounting Style A) For Slip Fit Application

- Proper alignment of the target magnet to the encoder sensing element is critical for optimal encoder performance. Insure that the target magnet is mounted to the specified height shown in the diagram below.
- A machined step on the motor shaft provides a quick and repeatable method for positioning the target magnet. Spacers or other fixturing should be used to properly position the target magnet if no mechanical locating features are on the shaft.
- Various adhesives can be used to bond the target magnet to the motor shaft. Shaft alloys, operating environment, and shaft speed and acceleration should be taken into consideration when selecting an appropriate bonding agent. Loctite threadlockers and retaining compounds have proved effective in bonding the target magnet to the motor shaft. Loctite 263 and 2760 threadlockers and Loctite 638 and 680 retaining compounds are good candidates. These materials have been effective in past experience; testing under actual operating conditions should be used to qualify any bonding material.
- For best results, the motor shaft should be clean and free of any oils, lubricants, or solvents.
- Apply adhesive around the leading edge of the shaft and inside the hole in the target magnet. Use a rotating motion when assembling the target magnet to the shaft to insure good adhesive coverage.
- The use of primers and activators can be used to improve bond strength and cure rate.
- For non-critical applications or for fast bonding for evaluation, a cyanoacrylate adhesive (super glue) can be used. Loctite 401 and 410 have proven effective for quick bonding applications.

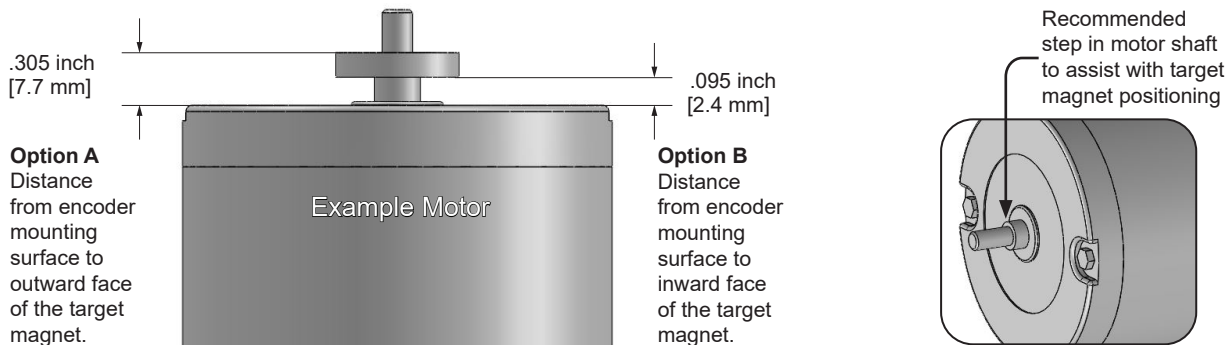

Target Magnet Physical Outline - Aluminum Hub (Mounting Style B)

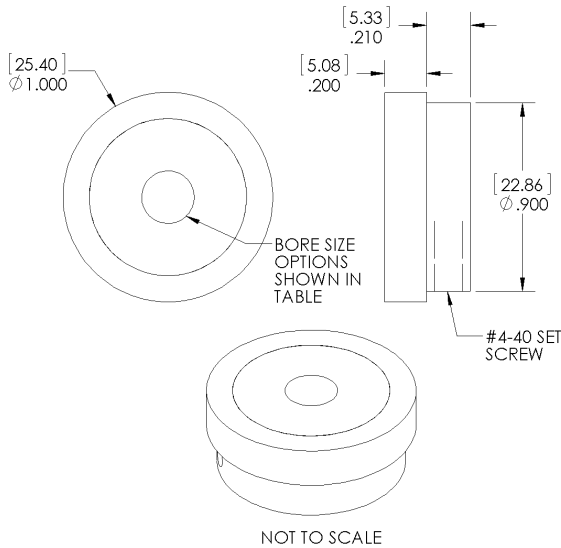

Table 6.1

Bore Size (.inch)	Motor Shaft OD Size (nominal)	NEMA Guide Shaft Tolerance	Magnet Bore MIN. (inch)	Magnet Bore MAX. (inch)
079	2 mm (.0787")	+0.0000"/-0.0005"	.0794	.0803
118	3 mm (.1181")		.1188	.1197
125	1/8 in (.1250")		.1257	.1266
156	5/32 in (.1563")		.1570	.1579
157	4 mm (.1575")		.1582	.1591
188	3/16 in (.1875")		.1882	.1891
197	5 mm (.1969")		.1976	.1985
236	6 mm (.2364")		.2371	.2380
250	1/4 in (.2500")		.2507	.2516
276	7 mm (.2758")		.2767	.2778
313	5/16 in (.3125")		.3134	.3145
315	8 mm (.3150")		.3159	.3170
375	3/8 in (.3750")		.3759	.3770
394	10 mm (.3940")		.3949	.3960
473	12 mm (.4728")		.4737	.4748
500	1/2 in (.5000")		.5009	.5020

Other bore sizes available upon request.
Contact sales@phoenixamerica.com.

Target Magnet Mounting Guidelines - Aluminum Hub (Mounting Style B)

- Proper alignment of the target magnet to the encoder sensing element is critical for optimal encoder performance. Insure that the target magnet is mounted to the specified height shown in the diagram below.
- A machined step on the motor shaft provides a quick and repeatable method for positioning the target magnet. Spacers or other fixturing should be used to properly position the target magnet if no mechanical locating features are on the shaft.
- While the hub is held in the proper position, use a .50 inch hex wrench to tighten #4-40 set screw.
- For permanent applications, a threadlocker or retaining compound is advised in conjunction with the set screw.

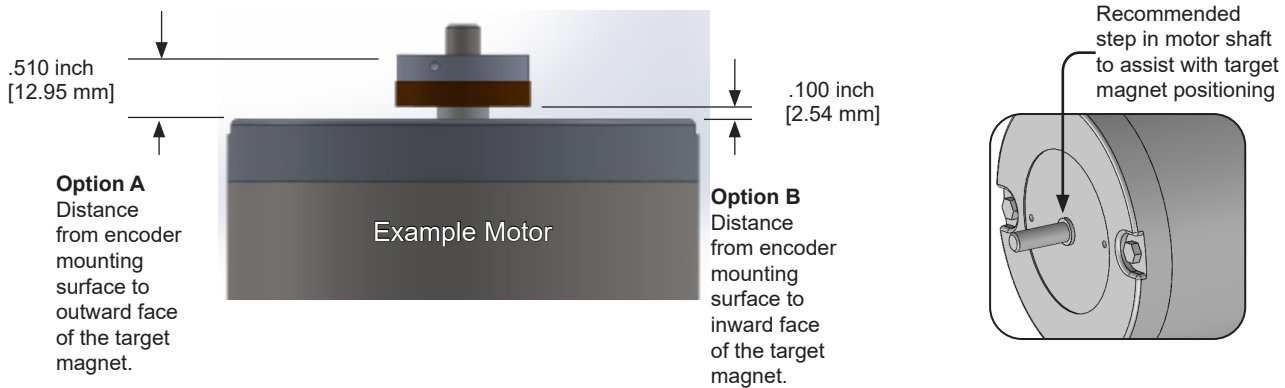

Target Magnet Physical Outline - Engineered Polymer Hub (Mounting Style H)

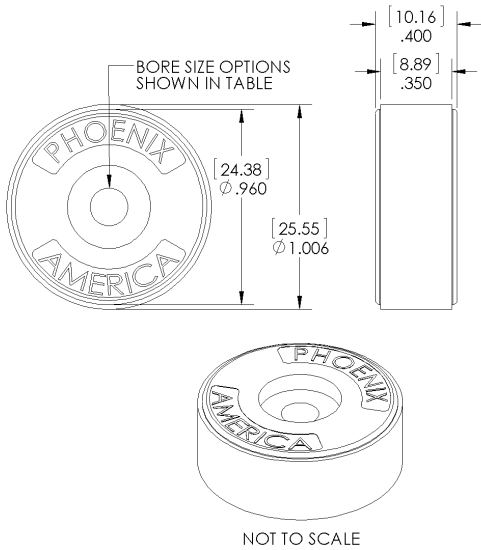

Table 7.1

Bore Size (.inch)	Motor Shaft OD Size (nominal)	NEMA Guide Shaft Tolerance	Magnet Bore MIN. (inch)	Magnet Bore MAX. (inch)
079	2 mm (.0787")	+0.0000"/-0.0005"	.0727	.0757
118	3 mm (.1181")		.1121	.1151
125	1/8 in (.1250")		.1190	.1220
156	5/32 in (.1563")		.1503	.1533
157	4 mm (.1575")		.1515	.1545
188	3/16 in (.1875")		.1815	.1845
197	5 mm (.1969")		.1909	.1939
236	6 mm (.2364")		.2304	.2334
250	1/4 in (.2500")		.2440	.2470
276	7 mm (.2758")		.2698	.2728
313	5/16 in (.3125")		.3065	.3095
315	8 mm (.3150")		.3090	.3120
375	3/8 in (.3750")		.3690	.3720
394	10 mm (.3940")		.3880	.3910

Other bore sizes available upon request.
Contact sales@phoenixamerica.com.

Target Magnet Mounting Guidelines - Engineered Polymer Hub (Mounting Style H) For Press Fit Application

- Proper alignment of the target magnet to the encoder sensing element is critical for optimal encoder performance. Insure that the target magnet is mounted to the specified height shown below.
- A machined step on the motor shaft provides a quick and repeatable method for positioning the target magnet. Spacers or other fixturing should be used if no mechanical locating features are on the shaft.
- A chamfered lead in on the shaft will aid in aligning the target magnet.
- Prior to insertion, the motor shaft should be clean and free of any oils, lubricants, or solvents.
- Proper fixtures and support must be used to ensure the target magnet is pressed on straight and aligned with the motor shaft.
- Opposite end of motor shaft should be supported to avoid undue stress on motor bearings during the pressing operation.
- In applications with high torque or environmental extremes, a retaining compound can be used to enhance the strength of the press fit.

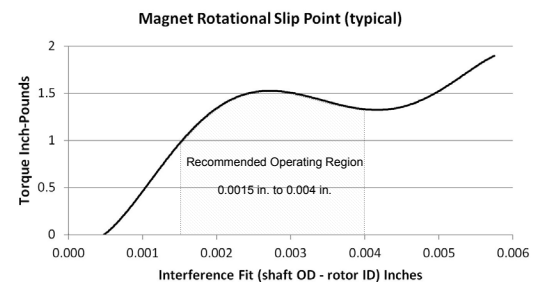
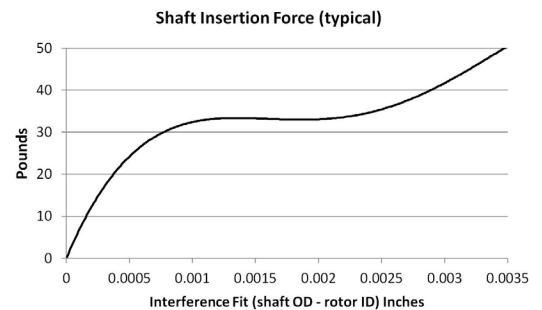

Target Magnet Physical Outline - Universal Hub (Mounting Style U)

A universal hub kit is available to accommodate both metric (2, 4, 5, 6 & 8mm) and inch (1/8, 3/16, 1/4, 5/16 & 3/8 In.) industry standard shaft diameters.

Kit contents (*not shown to scale*)

Includes 2 of each size for closed cover option.

Includes 3 of each size for shaft pass-through option.

Hubs

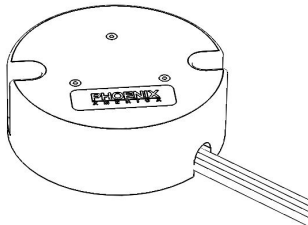
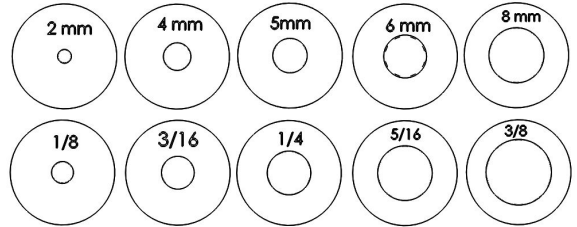

Encoder



Magnet Insertion Tool

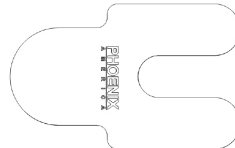

Spacer Gap Tool

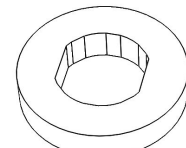

Target Magnet

Assembly Guidelines

Without shaft pass-through option

Step 1

Attach two of the desired hub size on each side of the magnet. Make sure the flats are in-line with each other.

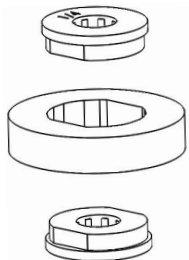

Step 2

Use the insertion tool to push the magnet assembly straight onto the shaft until the bottom face of the hub is resting on the gap tool.

tip - Support the bottom of the motor with a fixture or holding clamp.

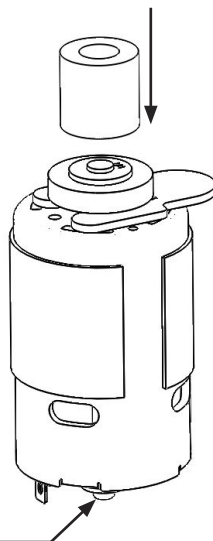

Step 3

Place the encoder onto the motor and secure with #2 or M2 screws.

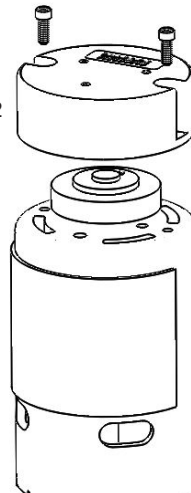

Step 4

Manually spin the shaft to verify that the shaft/magnet is not interfering with the encoder.

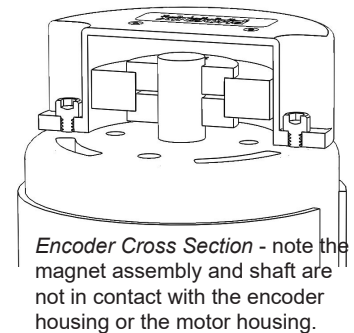

Encoder Cross Section - note the magnet assembly and shaft are not in contact with the encoder housing or the motor housing.

With shaft pass-through option

Step 2a

Insert an additional hub piece as shown. This is used as a fill-spacer to match the opening in the encoder housing.

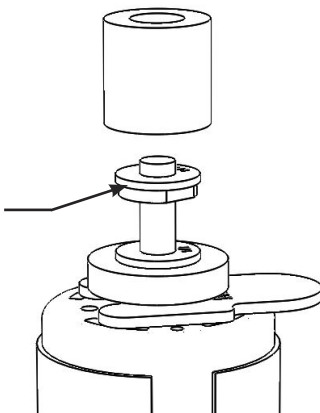

Step 3a

Place the encoder onto the motor and secure with #2 or M2 screws.

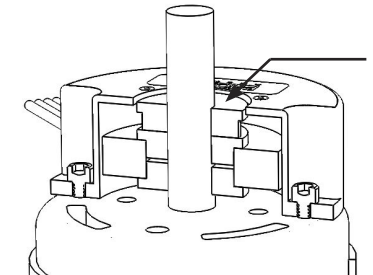
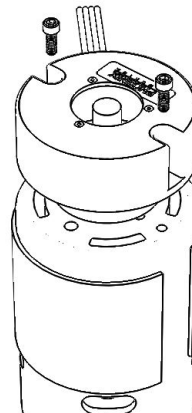

Encoder Cross Section - note the top face of the filler hub should be slightly below the top face of the encoder housing as shown by the arrow pointer.

Wiring (Single ended option depicted)

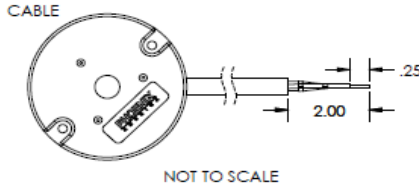
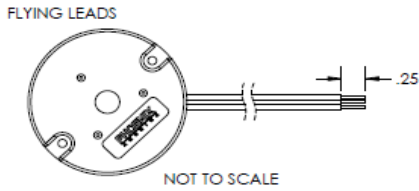

- 24 AWG
- 7x32 Strands, Tinned Copper
- PVC Insulation
- MIL M16878/1
- Temperature Rating: 105°C

- 24 (or 26) AWG
- 4 (or 6) Conductor with Foil Shield and Drain
- Stranded Tinned Copper
- PVC Insulation
- Grey PVC Jacket
- UL Style 2464, CSA
- Temperature Rating: 105°C

Table 9.1

Single Ended Wiring			
	Leads	Cable	Connector Pin-Out
Ch A	Yellow	Brown	1
Ch B	Blue	Orange	2
Gnd	Black	Black	3
Vcc	Red	Red	4
Z	Purple	—	5
Differential Wiring			
	Leads	Cable	Connector Pin-Out
Ch B	Blue	Orange	1
Ch B-	Orange	Green	2
Ch A	Yellow	Brown	3
Ch A-	Brown	Yellow	4
Gnd	Black	Black	5
Vcc	Red	Red	6

Custom lengths and insulation materials available. Contact sales@phoenixamerica.com.

Connector Options (Single ended option depicted)

Molex Mini-Fit Jr. (Male)

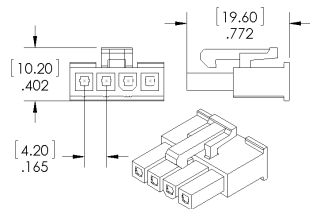

Molex Mini-Fit Jr. (Female)

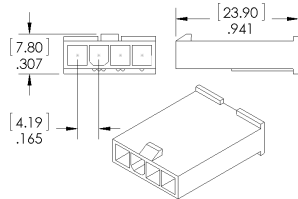

TE AmpModu MTE (Male)

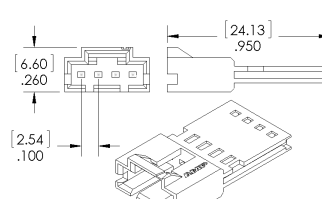

TE AmpModu MTE (Female)

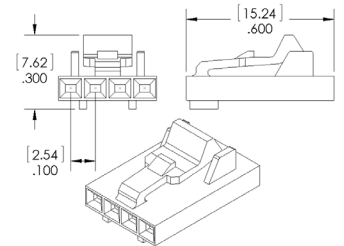

Need a different connector? Contact sales@phoenixamerica.com.

Part Number Description

H6 - 0128 - 0125 - 05 - A - N - H - F - B - XX

Series	PPR	Bore Size	Supply Voltage	Index/Output Type	Shaft Pass Through Hole	Target Magnet Mounting	Wiring	Length (Meters)	Connector
H6	0032	0240	1000	0079 2mm	05 5V (default)	A Molded	F Flying Leads (default)	A .5 (19.685")	XX None (default)
	0040	0250	1024	0118 3mm					
	0050	0256	1200	0125 1/8 in	24 24V in 5V out	Y Hole size will match Table 4.1	C 1 (39.370")	A2 TE AmpModu MTE (Female)	
	0056	0300	1250	0156 5/32 in					C AB Differential
	0060	0360	1280	0157 4mm	D ABZ Differential	U Universal Hub		M2 Molex Mini-Fit Jr. (Female)	
	0064	0384	1440	0188 3/16 in (default)					
	0080	0400	1500	0197 5mm					
	0096	0480	1600	0236 6mm					
	0100	0500	1650	0250 1/4 in					
	0120	0512	1800	0276 7mm					
	0128	0600	2000	0313 5/16 in					
	0150	0680	2100	0315 8mm					
	0160	0720	2400	0375 3/8 in					
	0180	0768	2480	0394 10mm					
	0192	0800	2500	0473 12mm					
	0200	0900	2560	0500 1/2 in 0000*					

*Universal Hub

Example: H6-0128-0125-05-A-N-H-F-B-X